

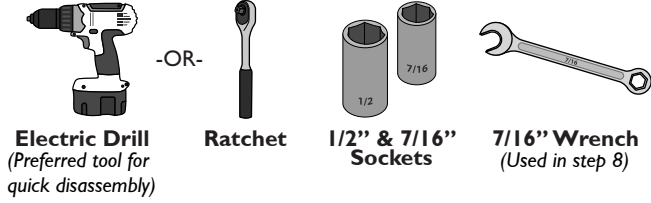

Version 6 Comfort Sleeper Complete Disassembly

No "T" Style Back

Tools needed to completely disassemble Version 6 Comfort Sleeper:



Electric Drill
(Preferred tool for quick disassembly)

Ratchet

1/2" & 7/16" Sockets

7/16" Wrench
(Used in step 8)

5/16" Bolt
(1/2" Head)



Twenty (20) total 5/16" Bolts removed during disassembly.

1/4" Bolt
(7/16" Head)



Four (4) total 1/4" Bolts removed during disassembly.

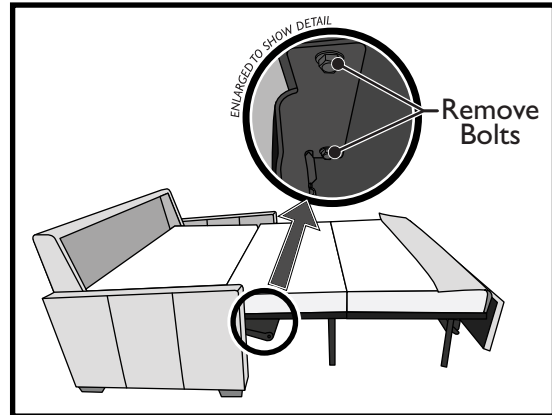

1. To begin, open the comfort sleeper as shown. Remove the two bolts connecting the middle bed section to the mechanism, as shown in the enlarged view. Do this on both the left and right sides.

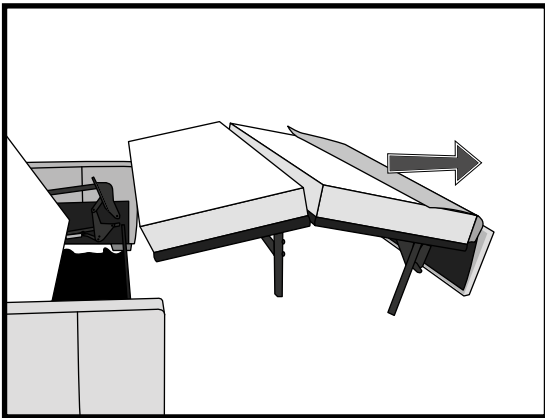

2. With the four (4) bolts removed, lift the front bed sections away from the comfort sleeper and set aside.

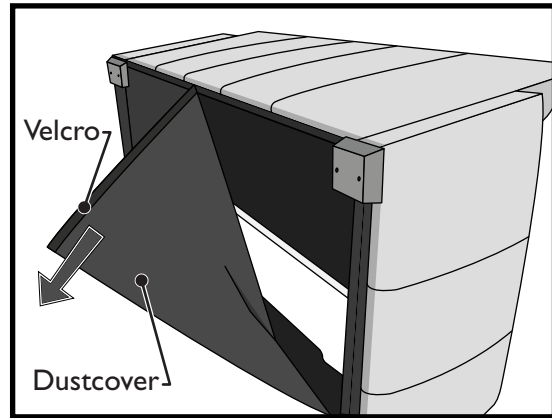

3. Roll the comfort sleeper forward, as shown. Open the dustcover on the bottom by pulling to release the velcro holding it closed.

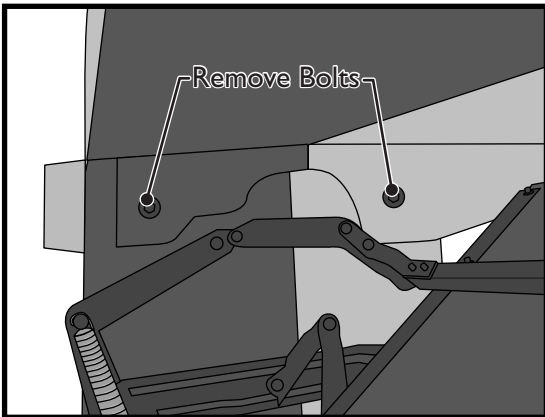

4. With the dustcover open, you have access to the bolts securing the back to the arms. Remove the two bolts, as shown in the figure above, from both sides of the comfort sleeper.

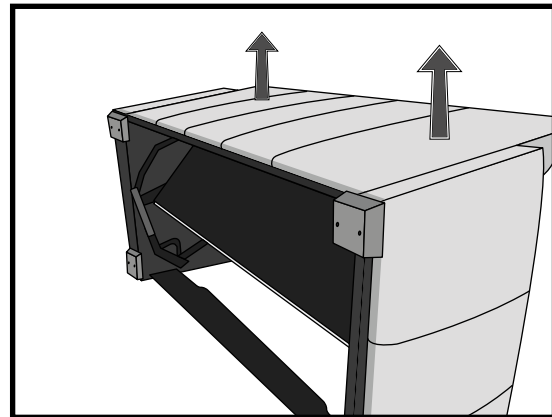

5. With the four bolts removed (from the previous step), the back can now be lifted away from the sleeper and set aside.



Version 6 Comfort Sleeper Complete Disassembly

No "T" Style Back

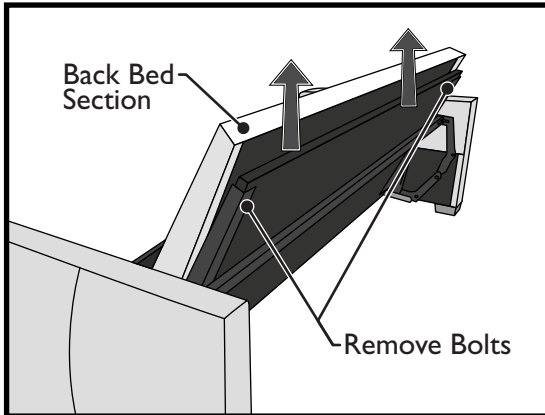

6. Remove (4) four bolts on each side of the comfort sleeper that secure the back bed section to the mechanism. Start from the bottom, leaving a single top bolt on each side. Hold the back bed section while removing the last two bolts. Set the back bed section aside.

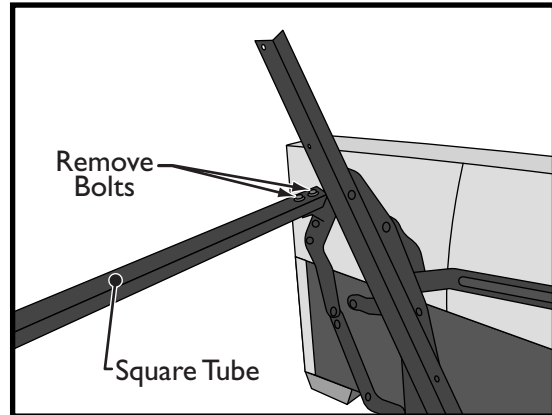

7. To remove the square tube, remove the two bolts on both sides of the comfort sleeper. With all (4) four bolts removed, set the square tube aside.

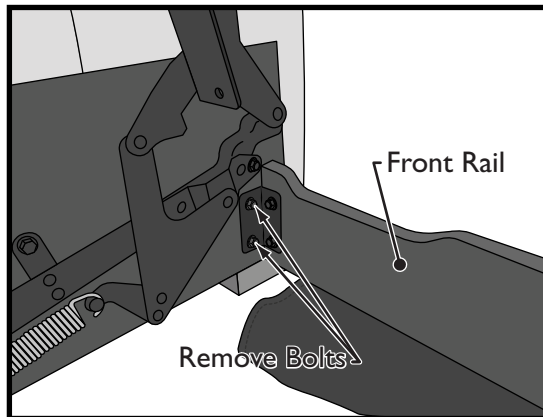

8. Remove the two bolts on each side of the comfort sleeper that secure the front rail to the arm. With the bolts removed, set the front rail aside.

Completely Disassembled:

